

Wall Pack Series

**Dart Round Bulkhead
Half-Cutoff Frame**



WPR22HC

Housing:

Die Cast Aluminum Housing & Half-cutoff Front Frame, Textured Powdercoat Finish Over a Chromate Conversion Coating, Gasketed

Reflector:

White Powdercoat Steel Pan Reflector

Lens:

LumaLens Polycarbonate Opal Lens

Socket:

PL: Plug-In Type, GX24Q-4

Mounting:

Surface Mount

Wattage:

Compact Fluorescent: 2 x 26 to 42w

Battery Backup:

Ninety Minute Battery Backup Available.

Listing & Ratings:

CSA: Listed for Wet Locations, Wall Mount Only.

Add: Battery Backup Available (Sold Separately)

Other Wattages & Custom Colors Available Upon Request.

Kit(s)				
Catalog #	Description			
WPR22HC*	Dart Round Half Cutoff Bulkhead, Twin Fluorescent Kit			
Complete Units (Lamp Included)				
Catalog #	Wattage	Voltage	Lamp	Ballast
WPR22HCF52EL *⌘	2 x 26	120-277	PL	Electronic
WPR22HCF64EL *⌘	2 x 32	120-277	PL	Electronic
WPR22HCF84EL *⌘	2 x 42	120-277	PL	Electronic
*Specify Color: BZ=Bronze, WH=White				
⌘Battery Backup Option: BU				

WP



Also Available in LED.

DIMENSIONS

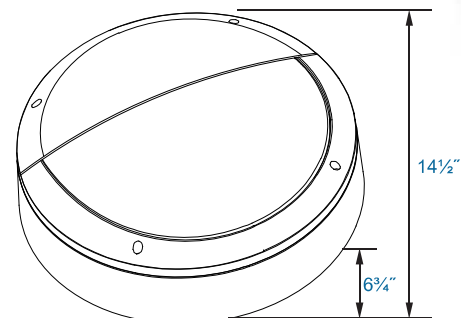

WPR22HC

BIEBER ILLUMINATION GROUP

garybieber@yahoo.com
www.bieberillumination.com
Phone: (310) 451-5589
Po Box 49303
Los Angeles, CA. 90049

WP

Catalog #	Description
3EB120277	Battery Backup Pack, 120-277V

Wall Pack Series

**Dart Round Bulkhead
Half-Cutoff Frame**



3EB120277

PHOTOMETRICS

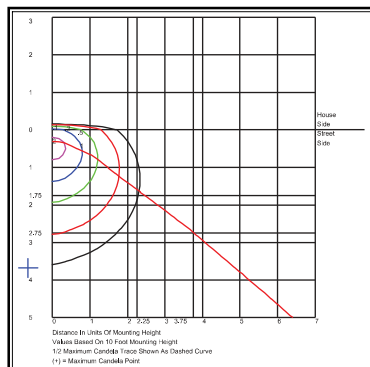

WPR22HCF84EL

BIEBER ILLUMINATION GROUP

garybieber@yahoo.com
 www.bieberillumination.com
 Phone: (310) 451-5589
 Po Box 49303
 Los Angeles, CA. 90049